

Features

The Resistance evaluator 600213 is a Safety-switching unit, designed for monitoring a Contact-Duo Safety-edge with an end terminating 8,2 KOhm Resistor. The Typ-Serie 600213 has a full redundant evaluation with redundance monitoring. The Safety-edge controlled the STOP relay output (13,14) with 2 forced safety relays. The additional two-way contact (31,32,34) is an auxiliary contact. The safety system conforming to the standards according **ZH1/494** and **EN 954-1 Cat.3** (Machine-safety components in control units), **EN 1760-2** (Pressure-sensitive safety devices).

Construction, Connections

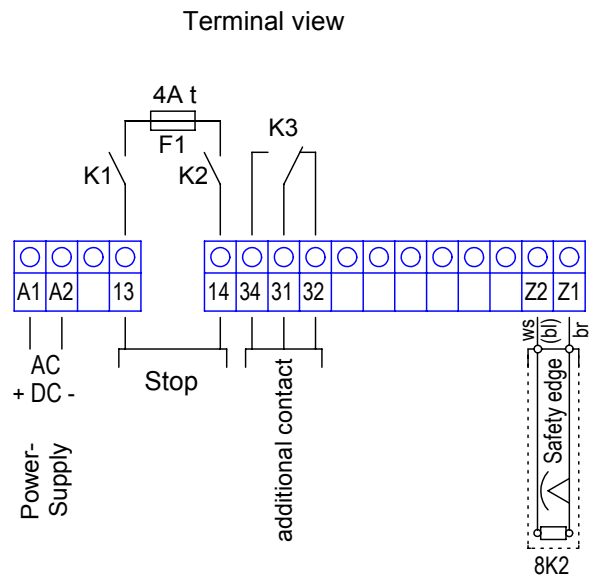
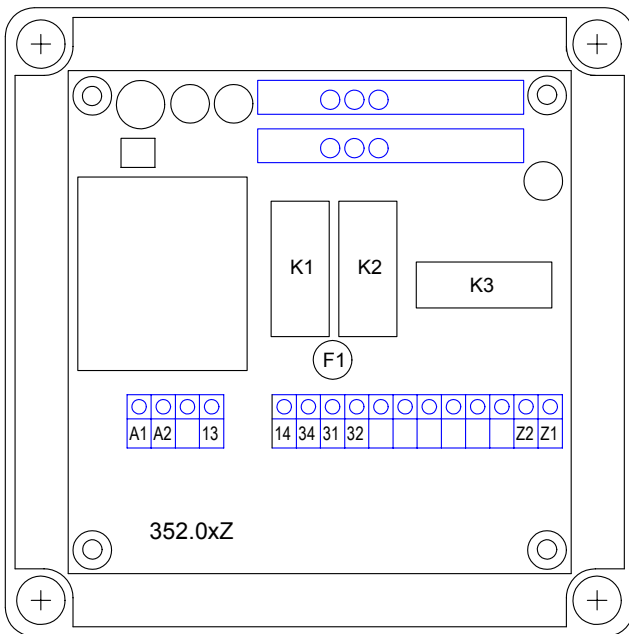

Function

The safety-contact-edge is connected to the terminals Z1-Z2. A closed-circuit current is monitored by an evaluator with safety switch outputs. By correct connections in ready-mode the safety-contacts 13,14 are closed and the green LED's on. If the safety-contact-edge is activated (pressed), the relays K1,K2 de-energizing and the safety-contacts are open. The red LED's shows this status. By an interrupted loop-current (Sensor on Z1,Z2 not connected) the yellow LED's are in on-state. The safety contacts 13,14 are open. The additional two way-contact (31,32,34) is swiching syncron to the STOP-contact (13,14). **Important:** This contact (31, 32, 34) only is an auxiliary-contact and not designed for safety-switch circuits.

Function table (status indication)

Sensor-profile condition	LED's red	LED's yellow	LED's green	Output 13,14
Correct connected, not activated			on *	closed
Sensor activated (pressed)	on			open
Sensor interrupted		on		open

* The green LED's shows the sensor-profile condition and not the output-contact status.

Assembly, Application

1. The housing is mounting about 4 bottom-drillings (mounting dimensions 115x115mm). For protection-class IP65, PG-threads with sealings are required.
2. The Contact-Duo Safety edge with an end-terminated resistor becomes connected to the Terminals Z1,Z2 . In this configuration,important is that the brown wire is connected to terminal Z1 and the white (blue) connected to terminal Z2. More than 1 safety-edges can connected serial with an end-resistor only terminated to the last sensor. (brown out to brown in and white out to white in)
3. The Safety-relay outputs 13, 14 and the additional auxiliary-contact 31,32,34 may be loaded with max. 4A (AC). The max. switching voltage for all contacts is 250V (AC).
4. Power supply must be connected to terminals A1 and A2. The phase-wire (+) is connected to A1.

The installation of this device may be implemented only by adept persons who dispose of the correspondending qualifications.

Problems and mistake search

1. no LED shines
Is the power supply correct?
2. both yellow LEDs shines constantly.
is the contact edge connected correctly or is a break in the connection cable?
Test: switch shortly 8,2K resistors between Z1–Z2 .
if function o.k. then ⇒ connection cable break.
3. both red LEDs shine constantly
disconnect contact edge and examine with an ohm-measuring device the contact edge resistance.
if the value is lower then 8K2, a short-circuit in the connection cable is possible.
4. both channels shows different status.
⇒device back to your dealer for control and repair.

Technical data

Housing:

Material: Polycarbonate with transparent cover.
 Protection class: IP65
 Dimensions: 130x130x75mm
 Mounting dimensions: 115x115mm
 Weight: ~ 600g

Supply voltages AC:

Typ **352.00Z**
 Nominal operating voltage: 230V -15/+10%
 Nominal frequency: 50Hz 40-60Hz

Power consumption: max. 5VA
Potential insulation: acc.VDE 0551

Supply voltage DC:

Typ **352.06Z**
 Nominal operating voltage: 24V -15/+10%
 Max. ripple: 10%

Power consumption: max. 5 W
Potential insulation: DC-DC Converter with transformer acc.VDE 0551

Sensor terminals Z1,Z2 :

End-terminal resistor 8K2
 Terminal voltage at break 8V DC
 In activated condition (pressed) < 4V DC
 In ready mode (not activated) < > 5V DC
 Closed-circuit current (not activated) 0,6mA
 Switching-resistance for activation < 5K5
 Switching-resistance for break >11K5

max. contact-edge length 100m

max. connection-cable length 50m
 connecting wires min. 0,5mm²
 (solid or with sleeves)

Safety-contacts 13,14

Contact-type **600213** **2 forced Safety-relays**
 each normally op serial
 out with build-in fuse 4A.

Reaction-time max. 15ms
 Contact-edge activated to relay-contact output.

Relay-contact data (13,14) (31,32,34)

Switching-voltage max. 250V AC
 Switching-capacity max. 1200VA
 max. 120W / 24V DC
 Switching-current 4A AC 11 230V
 2A DC 11 24V
 mech. durability 3 x 10⁷ switchings
 elektr. durability 2 x 10⁵ switchings

Operation temperatur -20°C / +55°C

Operation time 100%

Testing guidelines, standards:

- **EN 1760-2** „pressure-sensitive safety devices“
 (specific sections relating to the output-switching device)
- **EN 954-1** „Machine-safety components in control-units“
- **ZH 1/494**

Technical modifications reserved.